

# Panasonic

## *Quick Reference Guide*

Proprietary Telephone

Model No. **KX-AT7730**

---

Thank you for purchasing this Panasonic product.

Please read this manual carefully before using this product and save this manual for future use.

### **IMPORTANT NOTICE:**

Under power failure conditions, this telephone may not operate. Please ensure that a separate telephone, not dependent on local power, is available for use in an emergency.

### **Note**

- In this manual, the suffix of each model number is omitted.
- The illustrations may differ from the appearance of the actual product.
- For details, refer to the instructions for analogue proprietary telephones (such as the KX-T7700 series) in the Main Unit/PBX Manuals.

# ***Important Information***

---

## **For Users in the European Countries**

This product is intended to be connected to Panasonic KX series PBX only.

For information of Compliance with EU relevant Regulatory Directives,

Contact to Authorized Representative:

Panasonic Testing Centre

Panasonic Marketing Europe GmbH

Winsbergring 15, 22525 Hamburg, Germany

---

## **For Users in the United Kingdom**

- This unit is capable of being used in conjunction with hearing aids fitted with inductive coil pick-ups. The handset should be held as for normal conversation. For operation, the hearing aid should be set to its "T" position or as directed in the operating instructions for the hearing aid.
- This unit is designed to aid the visually handicapped to locate dial keys and buttons.
- This unit is designed to be installed under controlled conditions of ambient temperature and a relative humidity.
- Avoid installing the unit in damp or humid environments, such as bathrooms or swimming pools.
- 999 and 112 can be dialed on the product after accessing the outside line for the purpose of making outgoing calls to the BT emergency (999) and (112) services.



# Location of Controls

## RINGER Volume Selector

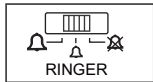

## LCD (Liquid Crystal Display)

**Panasonic**  
KX-AT7730

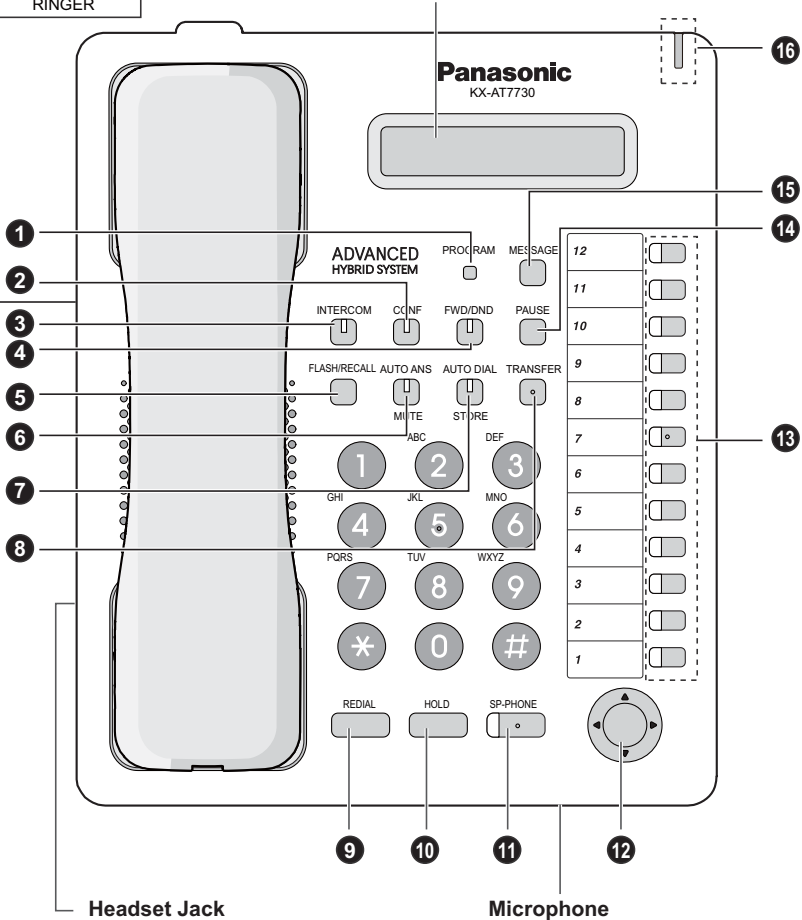

\* The headsets can be used with this unit. (Not all operations with the headsets can be guaranteed.)

For up-to-date information about headsets that have been tested with this unit, refer to the following web sites:

<https://panasonic.net/cns/pcc/support/pbx/>

# Location of Controls

---



- 1 **PROGRAM:** Used to enter and exit the programming mode.
- 2 **CONF (Conference):** Used to establish a multiple party conversation.
- 3 **INTERCOM:** Used to make or receive intercom calls.
- 4 **FWD/DND (Call Forwarding/Do Not Disturb):** Used to perform Call Forwarding or Do Not Disturb.
- 5 **FLASH/RECALL:** Used to disconnect the current call and make another call without hanging up.
- 6 **AUTO ANS (Auto Answer):**  
Used to receive an incoming call in the hands-free mode.  
**MUTE:** Used to mute the microphone during a conversation.
- 7 **AUTO DIAL/STORE:** Used for speed dialing or storing program changes.
- 8 **TRANSFER:** Used to transfer a call to another party.
- 9 **REDIAL (ordinarily):** Used to redial.
- 10 **HOLD:** Used to place a call on hold.
- 11 **SP-PHONE (Speaker Phone):**  
Used for the hands-free operation.
- 12 **Navigator Key:** Used to adjust the volume and the display contrast or select desired items for each function.
- 13 **Flexible Outside (CO) Line Button:**  
Used to make or receive an outside call. Pressing this button seizes an idle outside line automatically. (Button assignment is required.) Also used as the desired function buttons. (Button assignment is required.)
- 14 **PAUSE:** Used to insert a pause during dialing.
- 15 **MESSAGE:** Used to leave a message waiting indication or call back the party who left the message waiting indication.
- 16 **Message/Ringer Lamp:** The Message/Ringer lamp informs you visually that you have a message or a call.
  - When you receive a call, the lamp flashes depending on the ringing pattern. When someone has left you a message, the lamp is lit continuously.
  - When the ringing pattern is set to Single (Slow flash), Double (Moderate flash), or Triple (Rapid flash) in your PBX, the lamp flashes. When the other ringing patterns are set in your PBX, the lamp may not flash. (e.g., S-Double, Call Waiting Tone1).

# Initial Settings

---

## ◆ **Speaker volume** \*

*While in on-hook or during a conversation*

 → 

Press **SP-PHONE**.      Press **Up** or **Down**.

## ◆ **Handset/Headset volume** \*

*While using a handset or headset*



Press **Up** or **Down**.

## ◆ **Ringer volume**

*While in on-hook or receiving a call*

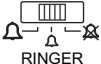

Slide the lever of the **RINGER** Volume Selector to the desired setting (**HIGH/LOW/OFF**).

## ◆ **Display contrast** \*

*While in on-hook or receiving a call*



























Press **Left** or **Right**.















\* The above settings may return to default settings if the telephone line cord is disconnected or the main unit's power is interrupted.

# Features List

 Outside (CO) Line button  
  Off-hook  
  On-hook  
  Feature number  
  Talk

Desired Function	Operation
<b>Making Calls</b>	
Calling	<p><b>To an extension</b>  ► <b>extension no.</b> ► </p> <p><b>To an external party</b>  ►  ► <b>phone no.</b> ► </p>
Redial	 ►  ► 
One-touch Dialing	<p><b>To program</b></p> <p>PROGRAM  ►  ► <b>2</b> ► <b>phone no.</b> ►  ► PROGRAM </p>
	<p><b>To dial</b></p> <p> ►  - assigned as a One-touch dialing button ► </p>
Calling an operator	 ► <b>0</b> ► 
Personal Speed Dialing	<p><b>To set</b></p> <p> ► <span style="border: 1px solid black; padding: 2px;"><b>2</b> <b>*</b></span> <input type="checkbox"/> KX-TE Series</p> <p><span style="border: 1px solid black; padding: 2px;"><b>*</b> <b>3</b> <b>0</b></span> <input type="checkbox"/> KX-TDA (excl. KX-TDA100D)/ KX-TDE/KX-NS/ KX-NCP/KX-NSX Series</p> <p>(Check the type of your Main Unit.)</p> <p>► <span style="border: 1px solid black; padding: 2px;"><b>desired no.</b></span> ► <span style="border: 1px solid black; padding: 2px;"><b>#</b></span> ► </p> <p style="text-align: right;"><span style="border: 1px solid black; padding: 2px;"><b>Personal speed dial no.</b></span> ►</p>
	<p><b>To dial</b></p> <p> ► <span style="border: 1px solid black; padding: 2px;"><b>#</b></span> <input type="checkbox"/> KX-TE Series</p> <p> ► <span style="border: 1px solid black; padding: 2px;"><b>*</b></span> <input type="checkbox"/> KX-TDA (excl. KX-TDA100D)/ KX-TDE/KX-NS/ KX-NCP/KX-NSX Series</p> <p>(Check the type of your Main Unit.)</p> <p style="text-align: right;"><span style="border: 1px solid black; padding: 2px;"><b>Personal speed dial no.</b></span> ► </p>
System Speed Dialing	<p><b>To dial</b></p> <p> ►  ► <span style="border: 1px solid black; padding: 2px;"><b>System speed dial no.</b></span> ► </p>

# Features List









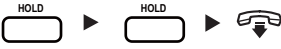
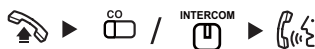
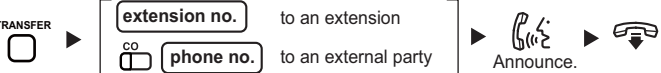

Desired Function	Operation	
<b>Receiving Calls</b>		
Hands-free answerback	<p><i>While on-hook</i></p> <p>AUTO ANS    MUTE</p>	
Picking up a call	<div style="border: 1px dashed black; padding: 10px;"> <p><b>Directed</b></p> <p><input type="checkbox"/> 4 extension no. <input type="checkbox"/> KX-TE Series</p> <p><input type="checkbox"/> * 4 1 extension no. <input type="checkbox"/> KX-TDA (excl. KX-TDA100D)/KX-TDE/KX-NS/KX-NCP/KX-NSX Series</p> <p><b>Group</b></p> <p><input type="checkbox"/> 4 0 <input type="checkbox"/> KX-TE Series</p> <p><input type="checkbox"/> * 4 0 group no. <input type="checkbox"/> KX-TDA (excl. KX-TDA100D)/KX-TDE/KX-NS/KX-NCP/KX-NSX Series</p> <p>(Check the type of your Main Unit.)</p> </div>	
<b>When the Dialed Extension is Busy/No Answer</b>		
Automatic Callback Busy	<p><b>To set</b> <i>While hearing a busy tone</i></p> <p><input type="checkbox"/> 6 </p> <p><b>To answer</b> <i>If you hear callback ringing</i></p> <p></p>	
Message Waiting	Sender	<p><b>To leave a notification</b></p> <p>MESSAGE </p> <hr/> <p><b>To cancel a notification</b></p> <p><input type="checkbox"/> KX-TE Series   extension no. MESSAGE MESSAGE </p> <p><input type="checkbox"/> KX-TDA (excl. KX-TDA100D)/KX-TDE/KX-NS/KX-NCP/KX-NSX Series   * 7 0 0 extension no. </p> <p>(Check the type of your Main Unit.)</p>
	Receiver	<p><b>To call back</b></p> <p> MESSAGE </p> <hr/> <p><b>To clear all notifications</b></p> <p><input type="checkbox"/> KX-TE Series   7 0 0 # </p> <p><input type="checkbox"/> KX-TDA (excl. KX-TDA100D)/KX-TDE/KX-NS/KX-NCP/KX-NSX Series   * 7 0 0 receiver's extension no. </p> <p>(Check the type of your Main Unit.)</p>

# Features List









Desired Function	Operation	
<b>When the Dialed Extension is Busy/No Answer</b>		
Call Waiting	Sender	<p><i>While hearing a busy tone</i></p> <div style="display: flex; align-items: center;"> <div style="border-left: 1px solid black; border-right: 1px solid black; padding: 0 10px;"> <input type="checkbox"/> <b>2</b> KX-TE Series  <input type="checkbox"/> <b>1</b> KX-TDA (excl. KX-TDA100D)/            KX-TDE/KX-NS/            KX-NCP/KX-NSX Series         </div> <div style="margin-left: 10px;">           ▶ Wait for an answer. ▶  </div> </div> <p>(Check the type of your Main Unit.)</p>
	Receiver	<div style="border: 1px dashed black; padding: 10px;"> <p><input type="checkbox"/> KX-TE Series</p> <p><b>For outside calls</b></p> <div style="display: flex; align-items: center;"> <div style="border-left: 1px solid black; border-right: 1px solid black; padding: 0 10px;"> <input type="checkbox"/> <b>7 3 1 1 #</b> Set  <input type="checkbox"/> <b>7 3 1 0 #</b> Cancel         </div> </div> <p><b>For intercom calls/doorphone calls</b></p> <div style="display: flex; align-items: center;"> <div style="border-left: 1px solid black; border-right: 1px solid black; padding: 0 10px;"> <input type="checkbox"/> <b>7 3 2 1 #</b> Set  <input type="checkbox"/> <b>7 3 2 0 #</b> Cancel         </div> </div> </div> <div style="display: flex; align-items: center; margin-top: 10px;"> <div style="text-align: center; margin-right: 10px;">             ▶         </div> <div style="border: 1px dashed black; padding: 10px; flex-grow: 1;"> <p><input type="checkbox"/> KX-TDA (excl. KX-TDA100D)/KX-TDE/KX-NS/            KX-NCP/KX-NSX Series</p> <p><b>For outside calls</b></p> <div style="display: flex; align-items: center;"> <div style="border-left: 1px solid black; border-right: 1px solid black; padding: 0 10px;"> <input type="checkbox"/> <b>* 7 3 2 1</b> Set  <input type="checkbox"/> <b>* 7 3 2 0</b> Cancel         </div> </div> <p><b>For intercom calls</b></p> <div style="display: flex; align-items: center;"> <div style="border-left: 1px solid black; border-right: 1px solid black; padding: 0 10px;"> <input type="checkbox"/> <b>* 7 3 1 1</b> Set  <input type="checkbox"/> <b>* 7 3 1 0</b> Cancel         </div> </div> </div> <div style="text-align: center; margin-left: 10px;">           ▶  </div> </div> <p>(Check the type of your Main Unit.)</p>
<p><b>To talk to the new party (While hearing the Call Waiting tone)</b></p> <div style="display: flex; justify-content: space-between;"> <div style="width: 45%;"> <p><b>Terminating a current status</b></p> <div style="display: flex; align-items: center;">  ▶  ▶  </div> </div> <div style="width: 50%; border-left: 1px dashed black; padding-left: 10px;"> <p><b>Holding a current status (outside call)</b></p> <div style="display: flex; align-items: center;"> <div style="border: 1px solid black; border-radius: 5px; padding: 2px 5px; margin-right: 5px;">HOLD</div> <div style="margin-right: 5px;">▶</div> <div style="border: 1px solid black; border-radius: 5px; padding: 2px 5px; margin-right: 5px;">CO</div> <div style="margin-right: 5px;">/</div> <div style="border: 1px solid black; border-radius: 5px; padding: 2px 5px; margin-right: 5px;">INTERCOM</div> <div style="margin-right: 5px;">▶</div> </div> <p><b>Holding a current status (extension)</b></p> <div style="display: flex; align-items: center;"> <div style="border: 1px solid black; border-radius: 5px; padding: 2px 5px; margin-right: 5px;">HOLD</div> <div style="margin-right: 5px;">▶</div> </div> </div> </div>		









# Features List

Desired Function	Operation
<b>During a Conversation</b>	
Holding a call	<p><b>Holding</b></p> 
	<p><b>To retrieve a call at the holding extension</b></p> 
	<p><b>To retrieve an outside call from another extension</b></p> 
Holding a call exclusively	<p><b>Holding</b></p>  <p><b>To retrieve a call on exclusive hold</b></p> 
Transferring a call	<p><b>TRANSFER</b></p>  <p>to an extension</p> <p>to an external party</p> <p>Announce.</p>
<b>Useful Features</b>	
Paging	<p><b>To page</b></p> <p><input type="checkbox"/> KX-TE Series</p> <div style="border: 1px dashed black; padding: 5px;"> <p><b>All extensions</b></p> <p><b>3 3 0</b></p> <p><b>Group</b></p> <p><b>3 3 group no.</b></p> <p><b>All external speakers</b></p> <p><b>3 4</b></p> <p><b>All extensions &amp; external speakers</b></p> <p><b>3 3 *</b></p> </div> <p>  Announce.</p> <p><input type="checkbox"/> KX-TDA (excl. KX-TDA100D)/KX-TDE/KX-NS/KX-NCP/KX-NSX Series</p> <p> <b>* 3 3 group no.</b>  Announce.</p>
	<p>You can make a voice announcement to extensions or external speakers or both in the preset group simultaneously.</p> <p><b>To answer an announced page</b></p> <div style="border: 1px dashed black; padding: 5px;"> <p><b>Through a telephone speaker</b></p> <p><b>4 3</b> <input type="checkbox"/> KX-TE Series</p> <p><b>* 4 3</b> <input type="checkbox"/> KX-TDA (excl. KX-TDA100D)/KX-TDE/KX-NS/KX-NCP/KX-NSX Series</p> </div> <p>  Announce.</p> <p>(Check the type of your Main Unit.)</p>
Three-party conference	<p><b>CONF</b></p> 

# Features List

Desired Function	Operation
<b>Useful Features</b>	
Setting Absent Message	 ▶ <span style="border: 1px solid black; padding: 2px;">7</span> <span style="border: 1px solid black; padding: 2px;">5</span> ▶ <span style="border: 1px solid black; padding: 2px;">message no.</span> <span style="float: right; margin-left: 20px;"><input type="checkbox"/> KX-TE Series</span> <span style="border: 1px solid black; padding: 2px;">*</span> <span style="border: 1px solid black; padding: 2px;">7</span> <span style="border: 1px solid black; padding: 2px;">5</span> <span style="border: 1px solid black; padding: 2px;">0</span> ▶ <span style="border: 1px solid black; padding: 2px;">message no.</span> <span style="float: right; margin-left: 20px;"><input type="checkbox"/> KX-TDA (excl. KX-TDA100D)</span> <span style="float: right; margin-left: 20px;"><input type="checkbox"/> KX-TDE/KX-NS/ KX-NCP/KX-NSX Series</span> (Check the type of your Main Unit.) ▶ <span style="border: 1px solid black; padding: 2px;">parameter (if required)</span> ▶ <span style="border: 1px solid black; padding: 2px;">#</span> ▶ 
Forwarding a call	<input type="checkbox"/> KX-TE Series  ▶  ▶ <span style="border: 1px solid black; padding: 2px;">1</span> ▶ <span style="border: 1px solid black; padding: 2px;">extension no.</span> <span style="border: 1px solid black; padding: 2px;">2</span> ▶ <span style="border: 1px solid black; padding: 2px;">extension no.</span> <span style="border: 1px solid black; padding: 2px;">3</span> ▶ <span style="border: 1px solid black; padding: 2px;">line access code</span> ▶ <span style="border: 1px solid black; padding: 2px;">phone no.</span> ▶ <span style="border: 1px solid black; padding: 2px;">#</span> ▶  <span style="border: 1px solid black; padding: 2px;">5</span> ▶ <span style="border: 1px solid black; padding: 2px;">your extension no.</span> <span style="border: 1px solid black; padding: 2px;">8</span> ▶ <span style="border: 1px solid black; padding: 2px;">your extension no.</span> <span style="border: 1px solid black; padding: 2px;">0</span> <input type="checkbox"/> KX-TDA (excl. KX-TDA100D)/KX-TDE/KX-NS/KX-NCP/KX-NSX Series  ▶ <span style="border: 1px solid black; padding: 2px;">*</span> <span style="border: 1px solid black; padding: 2px;">7</span> <span style="border: 1px solid black; padding: 2px;">1</span> <span style="border: 1px solid black; padding: 2px;">0</span> Both calls <span style="border: 1px solid black; padding: 2px;">1</span> Outside calls <span style="border: 1px solid black; padding: 2px;">2</span> Intercom calls ▶ <span style="border: 1px solid black; padding: 2px;">2</span> ▶ <span style="border: 1px solid black; padding: 2px;">extension no.</span> ▶ <span style="border: 1px solid black; padding: 2px;">#</span> <span style="border: 1px solid black; padding: 2px;">3</span> ▶ <span style="border: 1px solid black; padding: 2px;">extension no.</span> ▶ <span style="border: 1px solid black; padding: 2px;">#</span> <span style="border: 1px solid black; padding: 2px;">4</span> ▶ <span style="border: 1px solid black; padding: 2px;">extension no.</span> ▶ <span style="border: 1px solid black; padding: 2px;">#</span> <span style="border: 1px solid black; padding: 2px;">5</span> ▶ <span style="border: 1px solid black; padding: 2px;">extension no.</span> ▶ <span style="border: 1px solid black; padding: 2px;">#</span> <span style="border: 1px solid black; padding: 2px;">7</span> ▶ <span style="border: 1px solid black; padding: 2px;">your extension no.</span> <span style="border: 1px solid black; padding: 2px;">8</span> ▶ <span style="border: 1px solid black; padding: 2px;">your extension no.</span> <span style="border: 1px solid black; padding: 2px;">0</span> (Check the type of your Main Unit.) ▶ 
Clearing the setting	 ▶ <span style="border: 1px solid black; padding: 2px;">7</span> <span style="border: 1px solid black; padding: 2px;">9</span> <span style="border: 1px solid black; padding: 2px;">#</span> <span style="float: right; margin-left: 20px;"><input type="checkbox"/> KX-TE Series</span> <span style="border: 1px solid black; padding: 2px;">*</span> <span style="border: 1px solid black; padding: 2px;">7</span> <span style="border: 1px solid black; padding: 2px;">9</span> <span style="border: 1px solid black; padding: 2px;">0</span> <span style="float: right; margin-left: 20px;"><input type="checkbox"/> KX-TDA (excl. KX-TDA100D)/ KX-TDE/KX-NS/ KX-NCP/KX-NSX Series</span> (Check the type of your Main Unit.) ▶ 

# Features List

Desired Function	Operation
<b>Useful Features</b>	
Log-in/Log-out	<div style="border: 1px dashed black; padding: 10px;"> <p><input type="checkbox"/> KX-TE Series</p> <p>[ 7 3 6 0 # ] For Log-in</p> <p>[ 7 3 6 1 # ] For Log-out</p> <p><input type="checkbox"/> KX-TDA (excl. KX-TDA100D)/KX-TDE/KX-NS/ KX-NCP/KX-NSX Series</p> <p>[ * 7 3 6 1 ] For Log-in</p> <p>[ * 7 3 6 0 ] For Log-out</p> <p>[ ICD Group* extension no. Specified ]</p> <p>[ * All ]</p> <p>* ICD Group: Incoming Call Distribution Group (Check the type of your Main Unit.)</p> </div>
Do Not Disturb (DND)	<p><input type="checkbox"/> KX-TE Series</p> <p> <b>FWD/DND</b>  [ 4 Set ] [ 0 Cancel ]  # </p> <p><input type="checkbox"/> KX-TDA (excl. KX-TDA100D)/ KX-TDE/KX-NS/KX-NCP/ KX-NSX Series</p> <p> * 7 1 [ 0 Both calls ] [ 1 Outside calls ] [ 2 Intercom calls ] [ 1 Set ] [ 0 Cancel ] </p> <p>(Check the type of your Main Unit.)</p>
Locking your extension	<div style="border: 1px dashed black; padding: 10px;"> <p><input type="checkbox"/> KX-TE Series</p> <p>[ 7 7 lock code lock code # ] Lock</p> <p>[ 7 7 lock code # ] Unlock</p> <p><input type="checkbox"/> KX-TDA (excl. KX-TDA100D)/KX-TDE/KX-NS/ KX-NCP/KX-NSX Series</p> <p>[ * 7 7 1 ] Lock</p> <p>[ * 7 7 0 extension PIN* ] Unlock</p> <p>* PIN: Personal Identification Number (Check the type of your Main Unit.)</p> </div>

\* Consult your dealer for more details about the feature access numbers.

# Connection

---

## Note

- Panasonic assumes no responsibility for injuries or property damage resulting from failures arising out of improper installation or operation inconsistent with this documentation.

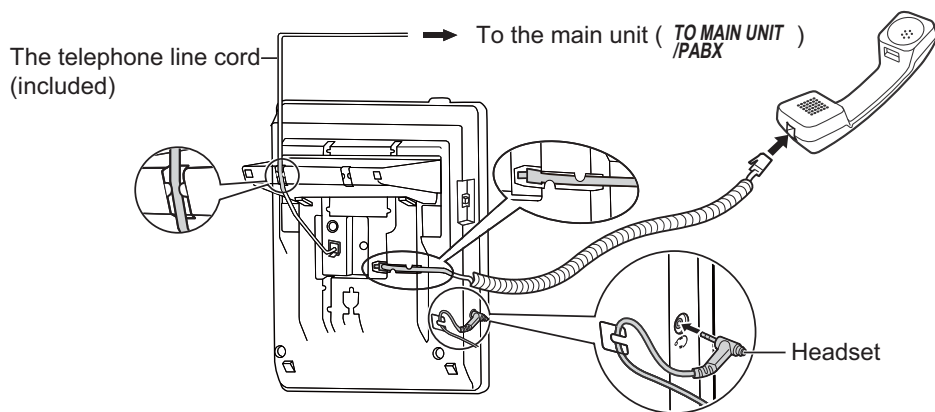

## CAUTION

Ensure the cord is inserted in the groove to prevent damage to the connector.

# Wall Mounting

- 1 Pull down the handset hook until it locks, so the tab holds the handset.

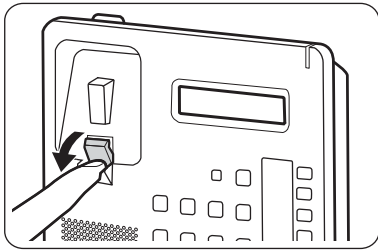

- 2 Remove the attached stand.

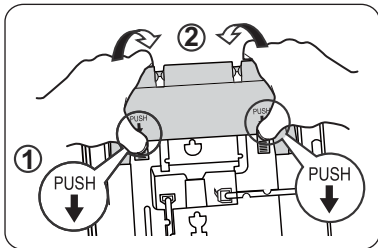

- 3 Mount the unit on the wall.

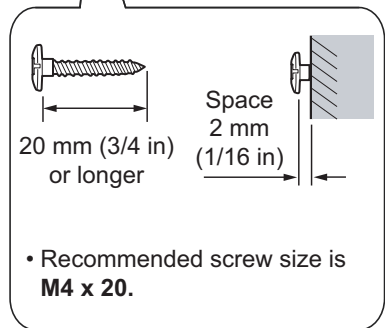
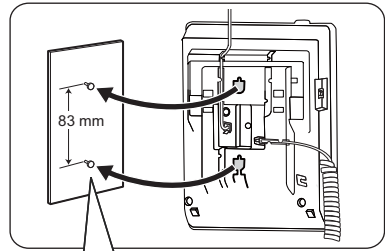

To temporarily place the handset down during a conversation, hook it over the top edge of the phone as shown.

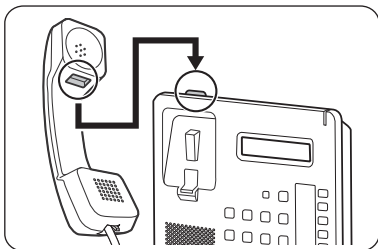

# Note

The tilt angle of the unit can be adjusted.

To adjust the angle, attach the stand to the desired position.

<LOW>

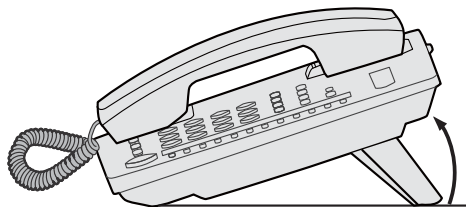

<HIGH>

